



## CITY OF COLWOOD

3300 Wishart Road | Colwood | BC V9C 1R1 | 250 478 5999  
[planning@colwood.ca](mailto:planning@colwood.ca) | [www.colwood.ca](http://www.colwood.ca)

File: DP-23-013

### DEVELOPMENT PERMIT DP-23-013

THIS PERMIT, issued August <sup>29<sup>th</sup></sup>, 2023 is,

ISSUED BY: **CITY OF COLWOOD**, a municipality incorporated under the *Local Government Act*, 3300 Wishart Road, Victoria, BC, V9C 1R1

(the "City")

PURSUANT TO: Section 490 of the *Local Government Act*, RSBC 2015, Chapter 1

ISSUED TO: **CACTUS DEVELOPMENTS**  
1175 Douglas Street  
7<sup>th</sup> floor  
Victoria, BC V8W 2E1

(the "Permittee")

- 
1. This Natural Hazards (Steeply Sloped) and Environmental (Hillside) Permit applies to those lands within the City of Colwood described below, and any and all buildings, structures, and other development thereon:

LOT B SECTION 63 ESQUIMALT PLAN VIP89431  
3469 Hopwood Place

(the "Lands");

2. This Development Permit regulates the development and alterations of the Land to enable site preparation for a 2-lot bareland strata subdivision and associated site improvements which are consistent with the Natural Hazard and Environmental guidelines for areas designated as "Steeply Sloped" and "Hillside" in the City of Colwood Official Community Plan (Bylaw No. 1700).
3. This Development Permit is **NOT** a Building Permit or a subdivision approval.
4. This Development Permit is issued subject to compliance with all of the bylaws of the City of Colwood that apply to the development of the Lands, except as specifically varied by Council or supplemented by this Permit.
5. The Director of Development Services or their delegate may approve minor variations to the plans and specifications attached to and forming part of this Development Permit, provided that such

minor variations are consistent with the overall intent of the original plans and do not alter the environmental conditions of the development authorized by those plans.

6. If the Permittee does not substantially start the construction permitted by this Permit within 24 months of the date of this Permit, the Permit shall lapse.
7. The development is to be constructed in accordance with the following plans and specifications, which are attached to and form as part of this permit:

Schedule 1	Environmental Assessment prepared by Corvidae Environmental Consulting Inc, dated July 2023.
Schedule 2	Geotechnical Report prepared by MGE Services Inc, dated June 7, 2023.
Schedule 3	Site Plan prepared by Westbrook Consulting Ltd, dated February 2023.
Schedule 4	Proposed Subdivision Plan prepared by J.E Anderson & Associates, dated March 15, 2023.

8. This Development Permit grants land alterations and site preparation to enable a 2-lot bareland strata subdivision along with any and all associated onsite works and improvements. The Land shall not be altered, nor any buildings or structures constructed, except in accordance with the following conditions:

#### **NATURAL HAZARD CONDITIONS**

##### **Geotechnical**

- 8.1. All geotechnical recommendations contained in the Geotechnical Report by MGE Services Inc (Schedule 2) must be followed under the guidance and approval of the Project Geotechnical Engineer.
- 8.2. Any and all retaining walls must be under 1.2m in height and be terraced at a minimum 1:1 ratio to the satisfaction of the Director of Development Services. Any over height retaining walls will be subject to a variance application.
- 8.3. The Project Geotechnical Engineer shall be contacted when structural filling is ongoing and must conduct periodic review of the fill placement and compaction procedure as outlined in the recommendations in Schedule 2.

#### **ENVIRONMENTAL CONDITIONS**

##### **Environmental Protection and Restoration**

- 8.4. All recommendations from the Environmental Assessment (Schedule 1) must be followed as outlined by Corvidae Environmental Consulting, including but not limited to invasive species removal with replacement of native species and plantings and placement of natural cover like logs or leafs for resident habitat enhancement and complexity.
- 8.5. Vegetation clearing must be completed outside of the migratory bird window (prior to March 15 or after August 31). If vegetation clearing is scheduled within the sensitive time period, a QEP must be contacted to conduct nest search surveys a maximum of 2-3 days before the start of activities.
- 8.6. A raptor nest survey must be completed by a QEP prior to clearing if scheduled between January 1 and August 15 as required by the Environmental Assessment (Schedule 1).

- 8.6.1. If any eagle or osprey nests are observed in trees to be removed, note that a separate permit is required.
- 8.7. Removal of invasive species timing windows shall be in substantial compliance per the Environmental Assessment (Schedule 1) under the guidance and approval of the Project QEP.

**Erosion and Sediment Control**

- 8.8. The following erosion and sediment control measures shall be adhered to per the recommendations of the Environmental Impact Assessment (Schedule 1):
- 8.8.1. No soil shall be left exposed for more than one growing season.
- 8.8.2. If erosion is detected during site preparation, silt fencing or straw wattles shall be installed to direct sediment to a holding area.
- 8.8.3. A large, labelled, mobile spill kit must be kept on-site during construction works and all construction equipment is kept in good working order without leaks.

ISSUED ON THIS 29<sup>th</sup> DAY OF AUGUST 2023

Yazmin Hernández B

YAZMIN HERNANDEZ, MCIP RPP  
DIRECTOR OF DEVELOPMENT SERVICES



# ENVIRONMENTAL ASSESSMENT

## FOR 3469 HOPWOOD PLACE, COLWOOD BC

PREPARED FOR:  
REX COBURN

AND

CITY OF COLWOOD  
3300 WISHART ROAD  
COLWOOD, BC, V9C 1R1

CORVIDAE PROJECT #2023-073  
JULY 2023

**CORVIDAE**  
ENVIRONMENTAL CONSULTING INC

6526 WATER STREET, SOOKE, BC

**TABLE OF CONTENTS**

**1 INTRODUCTION .....1**

1.1 OBJECTIVES .....4

1.2 REGULATORY FRAMEWORK .....4

1.3 DEVELOPMENT PERMIT AREAS .....5

**2 SCOPE OF WORK.....8**

**3 METHODS.....8**

3.1 DESKTOP REVIEW .....8

3.2 FIELD ASSESSMENT .....8

**4 ENVIRONMENTAL SITE ASSESSMENT.....9**

4.1 LAND USE.....9

4.2 CLIMATE AND BIOGEOCLIMATIC ZONE.....9

4.3 TERRAIN AND SOILS.....9

4.4 SURFACE WATER .....9

4.5 VEGETATION .....9

4.6 WILDLIFE .....10

4.7 SPECIES AT RISK .....11

**5 POTENTIAL ENVIRONMENTAL EFFECTS.....15**

**6 RECOMMENDED ENVIRONMENTAL PROTECTION MEASURES.....15**

**7 CONCLUSION.....19**

**8 REFERENCES .....20**

**APPENDIX A – SITE PHOTOGRAPHS .....22**

**LIST OF TABLES**

Table 1. Plant species observed on or near the site during the June 23, 2023, field visit. .... 10

Table 2. Wildlife Species observed on site during the June 23, 2023, field visit..... 11

Table 3. Species at risk that may occur in the vicinity of 3496 Hopwood Place, Colwood, BC. .... 11

Table 4. Recommended native vegetation species options for future enhancement. .... 16

Table 5. Removal and disposal methods for invasive species ..... 17

**LIST OF FIGURES**

Figure 1. Site Location .....2

Figure 2. Proposed Subdivision Plan.....3

Figure 3. Development Permit Areas .....7

Figure 4. Project area and mapped sharp-tailed snake habitat ..... 13



Figure 5. Species and ecosystems at risk occurrences in the vicinity of the Site ..... 14

**LIST OF PHOTOS**

Photo 1. Northwest view of site entrance and adjacent residential development. June 23, 2023. ....22

Photo 2. Southeast view of Site and existing vegetation. June 23, 2023 .....22

Photo 3. Northwest view looking back upslope into the Site. June 23, 2023.....23

Photo 4. North view of exposed, disturbed rock. June 23, 2023.....23

Photo 5. Scotch broom infestation, looking east. June 23, 2023 .....24

Photo 6. South view of adjacent cleared lot. June 23, 2023. ....24

Photo 7. Vegetation at top of slope along the eastern property edge near Veterans Memorial Parkway, looking southeast. June 23, 2023. ....25

Photo 8. View of Veterans Memorial Parkway from eastern site extent, looking northeast. June 23, 2023. ....25

**CAVEAT**

This Environmental Assessment (EA) has been prepared with the best information available at the time of writing, including the City of Colwood Official Community Plan, communications with the client, a site visit, review of site plans and design drawings and other documentation relevant to the project. This EA has been developed to assist the subdivision proposal in remaining in compliance with relevant environmental regulations, acts and laws and to identify and mitigate anticipated impacts of the proposed works.



# 1 INTRODUCTION

Corvidae Environmental Consulting Inc. (Corvidae) is pleased to provide this Environmental Assessment (EA) for the proposed subdivision of 3469 Hopwood Place in Colwood, BC (the Site) (PID: 028-916-221; LOT B, Plan VIP89431) into two bare land strata lots.

The lot is currently vacant and vegetated with predominantly non-native species, including large patches of scotch broom. The Site boundaries are shown in Figure 1, designated by the red polygon and the proposed subdivision plan is included as Figure 2. Specific, future development details have not been proposed at this time; however, site preparation activities following subdivision approval may include (but are not limited to) the following: vegetation removal, rock excavation (blasting), grading, and the installation of driveways, utility alignments, and retaining structures. The Site occurs within the Natural Hazards Development Permit Area (DPA) and the Hillsides Environmental Protection DPA (Figure 3) and is zoned as Residential 1 (R1).

Sensitive environmental features were not detected at the time of the assessment. Based on available imagery, the Site was cleared prior to 2013 in conjunction with other residential lots located along Hopwood Place and Residential Way. No surface water features or species and ecological communities at risk were detected on the site during the assessment. The Site includes an area of mapped potential habitat for sharp-tailed snake (Figure 4). The potential for sharp-tailed snake to occur is considered low based on previous disturbances on the site and current conditions (see section 4.5 of this report for further details).

This document addresses the requirements outlined in Part D of the City of Colwood Bylaw No. 1700, provides a detailed assessment on the environmental conditions on the Site, potential impacts of the proposed subdivision, and recommendations for the protection of environmentally sensitive features and methods to minimize impacts of the proposed works.





Site Location

 Project Boundary

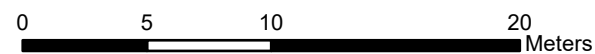

Project: 3469 Hopwood Place | Sources: Capital Regional District



Corvidae Project No.  
COR-2023-073

Rev. #	Date
0	July 7, 2023

**Figure 1**



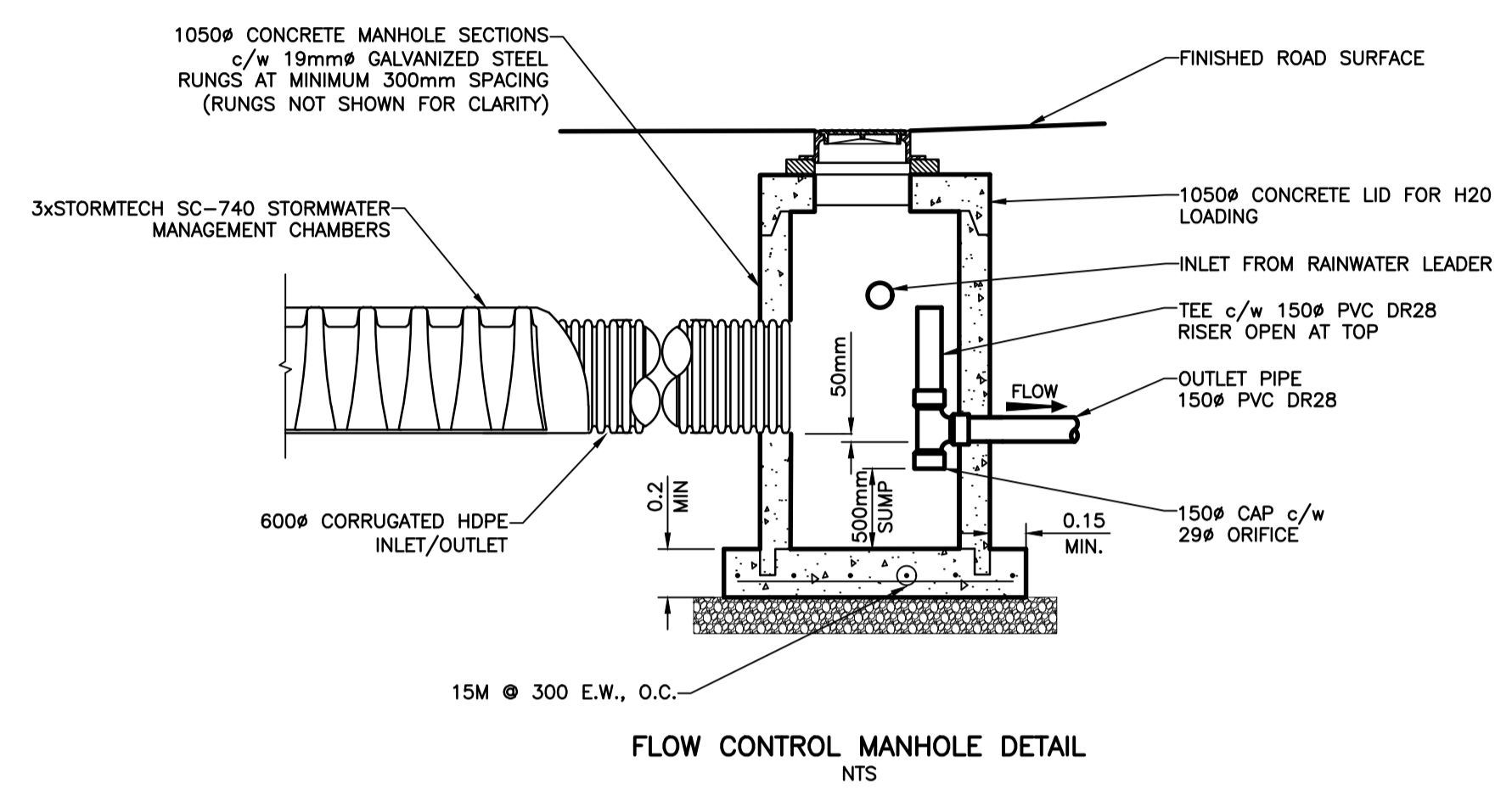
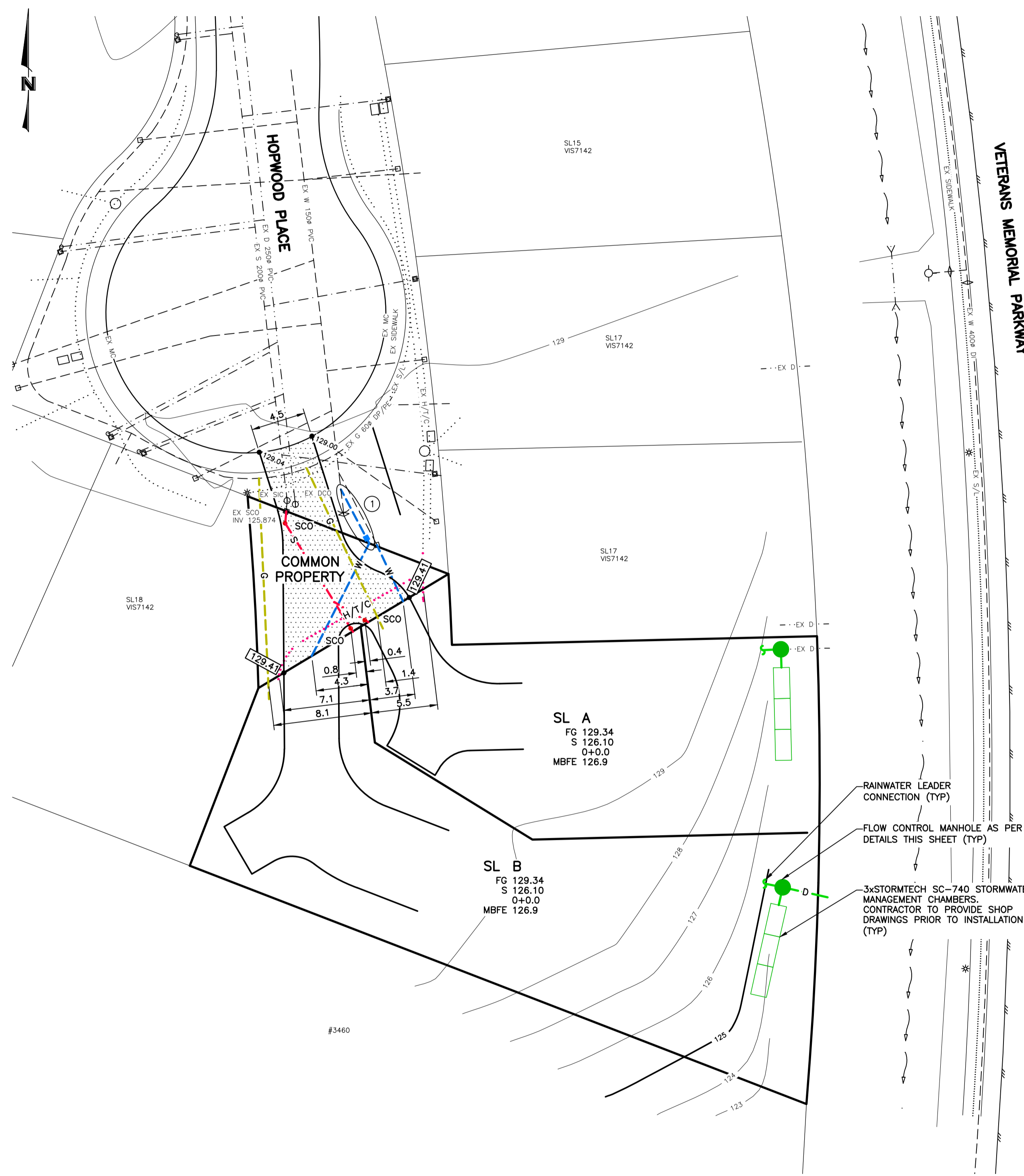

- GENERAL NOTES**
- ALL CONSTRUCTION AND MATERIALS SHALL BE IN ACCORDANCE WITH MMCD, LATEST EDITION, AND THE CITY OF COLWOOD STANDARD SPECIFICATIONS AND DRAWINGS UNLESS OTHERWISE NOTED.
  - WHEN A CONFLICT BETWEEN THE SPECIFICATIONS ARISES, THE MOST STRINGENT SHALL APPLY.
  - OBTAIN A PERMIT TO CONSTRUCT WORKS ON MUNICIPAL RIGHT OF WAY FROM THE CITY OF COLWOOD ENGINEERING DEPARTMENT SEVEN WORKING DAYS PRIOR TO THE START OF ANY CONSTRUCTION.
  - CONTACT BC HYDRO, TELUS, SHAW CABLE AND FORTISBC GAS THREE WORKING DAYS PRIOR TO THE START OF ANY EXCAVATION.
  - EXPOSE ALL EXISTING SERVICES AT CONNECTION AND CROSSING POINTS TWO WORKING DAYS PRIOR STARTING CONSTRUCTION ON ANY SUCH SERVICES. ENSURE ENGINEER HAS CONFIRMED THE HORIZONTAL AND VERTICAL LOCATION.
  - BED ALL PIPE USING CLASS 'B' BEDDING.
  - WHERE A TRENCH IS UNDER OR WITHIN 1.0m OF THE EDGE OF A ROAD OR DRIVEWAY, USE PIT RUN GRAVEL BACKFILL FROM THE TOP OF THE PIPE BEDDING TO THE TOP OF THE ROAD, PARKING OR DRIVEWAY SUBGRADE.
  - DO NOT START ANY BACKFILL OPERATION UNTIL THE WORKS HAVE BEEN INSPECTED BY THE ENGINEER.
  - AFTER CONSTRUCTION, RESTORE WORK AREAS AND ALL EXISTING FEATURES TO THEIR ORIGINAL CONDITION OR BETTER.
  - MAINTAIN VEHICULAR AND PEDESTRIAN ACCESS ALONG HOPWOOD PLACE DURING CONSTRUCTION.
  - COMPACT TRENCH BACKFILL, ROAD BASE AND DRIVEWAY BASE TO 95% MODIFIED PROCTOR DENSITY.
  - ADJUST ALL PROPOSED AND EXISTING APPURTENANCES TO MEET THE FINAL DESIGN GRADES.
  - ENSURE THAT ALL SERVICES TO THE EXISTING HOUSES REMAIN USABLE DURING CONSTRUCTION.
  - CONSTRUCT SEWER, DRAIN, WATER AND ROADS WITHIN PRIVATE PROPERTY IN ACCORDANCE WITH THE BC PLUMBING CODE AND BC BUILDING CODE. CONSTRUCTION SHALL BE INSPECTED AND APPROVED BY THE CITY OF COLWOOD INSPECTORS.
  - CONTRACTOR TO MAINTAIN A REDLINE MARKUP, ON SITE, OF THE WORKS INSTALLED THAT DAY.

- SEWER AND DRAIN**
- SEWER AND DRAIN SERVICE CONNECTIONS SHALL BE 100Ø PVC DR28 AT A MINIMUM GRADE OF 2.0% COMPLETE WITH INSPECTION CHAMBERS. CATCH BASIN LEADS SHALL BE 200Ø PVC DR35 UNLESS OTHERWISE NOTED. IF COVER IS LESS THAN 750mm, USE DUCTILE IRON PIPE.
  - SEWER AND DRAIN PIPE UP TO AND INCLUDING 150mm DIAMETER SHALL BE PVC DR28 AND DR35 FOR 200mm DIAMETER AND OVER. PIPE SHALL BE C.S.A. APPROVED PVC.
  - SEWER AND DRAIN MANHOLES SHALL BE 1050Ø BARRELS UNLESS OTHERWISE SPECIFIED.
  - CONNECT ALL ENCOUNTERED DRAINS TO THE PROPOSED SERVICE CONNECTION. CONTRACTOR TO RECORD THE LOCATION, ELEVATION, PIPE MATERIAL AND SIZE FOR THE RECORD DRAWINGS.
  - VIDEO INSPECT ALL INSTALLED SANITARY SEWER AND STORM DRAIN MAINS ON PUBLIC AND PRIVATE PROPERTY.

- WATER**
- CONSTRUCTION SHALL NOT PROCEED WITHOUT FIRST OBTAINING CRD WATER SERVICES ACCEPTANCE OF THE DESIGN DRAWINGS AND A CONSTRUCTION PERMIT FROM IHA.
  - CONTRACTOR SHALL BE REGISTERED WITH WORK SAFE BC.
  - ALL WATERWORKS CONSTRUCTION AND MATERIALS SHALL BE IN ACCORDANCE WITH CRD WATER SERVICES ENGINEERING SPECIFICATIONS AND STANDARD DRAWINGS.
  - PROVIDE A MINIMUM 0.9m COVER TO A MAXIMUM OF 1.2m COVER FOR WATER MAINS UNLESS APPROVED BY A CRD FORCES ENGINEER.
  - MAINTAIN A MINIMUM OF 3m HORIZONTAL CLEAR SEPARATION AND 450mm CLEAR VERTICAL SEPARATION BETWEEN WATER SERVICES AND SEWER SERVICES, SANITARY OR STORM/DRAIN, IN SPECIAL CIRCUMSTANCES, WHEN A SANITARY SEWER OR STORM DRAIN SERVICE IS LOWER THAN A WATER SERVICE BY MORE THAN 450mm IN ELEVATION THE HORIZONTAL OFFSET MAY BE REDUCED TO NO LESS THAN 1.0m EXCEPT WHERE NOTED AND APPROVED BY CRD WATER SERVICES. VIHA APPROVAL IS REQUIRED FOR ANY REDUCTION IN THE SEPARATION.
  - MAINTAIN A MINIMUM OF 1.0m HORIZONTAL CENTRE TO CENTRE AND 150mm CLEAR VERTICAL SEPARATION BETWEEN WATER SERVICES AND ELECTRICAL, GAS AND TELEPHONE SERVICES EXCEPT WHERE NOTED AND APPROVED BY CRD WATER SERVICES.
  - CONTRACTOR SHALL CONDUCT A PRESSURE TEST IN ACCORDANCE WITH CRD WATER SERVICES ENGINEERING SPECIFICATIONS AND IN THE PRESENCE OF CRD PERSONNEL.
  - NEUTRALIZE CHLORINE SOLUTIONS IN ACCORDANCE WITH MINISTRY OF ENVIRONMENT AND FISHERIES AND OCEANS CANADA REGULATIONS PRIOR TO DISCHARGE TO ANY DRAINAGE COURSE.
  - CONTRACTOR SHALL PROVIDE 24 HOUR NOTICE TO CRD WATER SERVICES PRIOR TO PROCEEDING WITH ANY WATERWORKS.
  - CRD WATER SERVICES SHALL INSTALL THE 25Ø WATER SERVICE AND METER TO THE PROPERTY LINE AT THE DEVELOPER'S EXPENSE.
  - CRD WATER SERVICES SHALL MAKE ALL CONNECTIONS TO EXISTING WATER MAINS AT DEVELOPER'S EXPENSE. CONTRACTOR SHALL PROVIDE 48 HOURS NOTICE TO CRD WATER SERVICES FOR WORK REQUIRED BY CRD WATER SERVICES FORCES.
  - WHERE PRACTICAL, SERVICE LINES AND METER BOXES SHALL BE INSTALLED TO FINISHED GRADE, OUTSIDE OF DRIVEWAYS OR PAVED AREAS.
  - ANY TEMPORARY OR PERMANENT CONNECTION TO THE JUAN DE FUCA WATER DISTRIBUTION SYSTEM OR THE CRD SUPPLY SYSTEM SHALL BE PERFORMED BY CRD WATER SERVICES PERSONNEL ONLY.

- ROAD**
- CONSTRUCT ALL ROADWAYS AND CUL DE SACS IN ACCORDANCE WITH THE CITY OF COLWOOD STANDARD SPECIFICATIONS AND AS SHOWN ON THE TYPICAL SECTION AND DETAIL DRAWINGS.
  - CONTRACTOR TO ENSURE EXISTING MONUMENTS ARE NOT DISTURBED DURING CONSTRUCTION. ANY MONUMENTS IN DANGER OF DISTURBANCE ARE SHALL BE REFERENCED BY AND, IF DISTURBED, BE REPLACED BY A B.C.L.S. AT THE CONTRACTOR'S EXPENSE.

- HYDRO, TELEPHONE, CABLE, STREET LIGHTING AND GAS**
- CONTACT "B.C. ONE CALL" AT 1-800-474-6886 AND "DIG SHAW" AT DIGSHAW.CA A MINIMUM OF THREE WORKING DAYS PRIOR TO START OF CONSTRUCTION.
  - LOTS SHALL BE SERVICED UNDERGROUND.
  - BC HYDRO, TELUS, SHAW CABLE AND FORTISBC FACILITIES ARE SHOWN SCHEMATICALLY ON THIS DRAWING. REFER TO UTILITY COMPANY DRAWINGS FOR CONSTRUCTION DETAILS.
  - CONSTRUCT UNDERGROUND HYDRO, TELEPHONE AND CABLEVISION AS SPECIFIED AND IN ACCORDANCE WITH BC HYDRO, TELUS AND SHAW CABLE STANDARD SPECIFICATIONS AND DRAWINGS.
  - IF GAS IS REQUIRED, THE DEVELOPER IS TO CONTACT FORTISBC AT 1-888-224-2710 A MINIMUM OF 90 DAYS PRIOR TO INSTALL. FORTISBC SHALL INSTALL GAS SERVICE TO THE PROPERTY LINE.



**LOCATION PLAN**  
N.T.S.

PROPOSED SUBDIVISION OF LOT B, SECTION 63,  
ESQUIMALT DISTRICT, PLAN VP89431

0 5 15m  
1:250

No.	DATE	REVISION	ENGR	EXISTING	PROPOSED	EXISTING	PROPOSED	EXISTING	PROPOSED	EXISTING	PROPOSED
1	23-06-13	SWMP REVISION	BB/IK	MANHOLE CLEANOUT LIFT STATION INSPECTION CHAMBER CATCH BASIN SILT TRAP SEEPAGE PIT CULVERT DITCH HYDRANT WATER VALVE FLUSH VALVE	MANHOLE WATER METER UTILITY MANHOLE SERVICE BOX LPT UTILITY POLE POLE-MOUNT LS ORNAMENTAL LUMINAIRE TRAFFIC SIGNAL	FM-SANITARY FORCEMAIN STORM DRAIN WATER GAS ELECTRICAL ROAD CURB EDGE OF PAVEMENT DRIVEWAY SIDEWALK PROPERTY LINE EASEMENT	SANITARY STORM DRAIN WATER GAS ELECTRICAL ROAD CURB EDGE OF PAVEMENT DRIVEWAY SIDEWALK PROPERTY LINE EASEMENT	FENCE SLOPE - TOP SLOPE - BOTTOM CONTOUR - MAJOR CONTOUR - MINOR BOUNDARY BUILDING ENVELOPE VEGETATION LINE	BENCHMARK: ELEVATION:		

**WESTBROOK Consulting Ltd.**

#115 - 866 Goldstream Ave., Victoria, BC V9B 0J3  
Telephone: 250-391-8592 Facsimile: 250-391-8593

**Colwood**

DESIGN IK  
DRAWN BB  
CHECKED  
ENGINEER MW

PROJECT: 3469 HOPWOOD PLACE	COLWOOD FILE NO. SUB22-012
TITLE: CACTUS DEVELOPMENTS LTD. SITE PLAN GENERAL NOTES	COLWOOD CONTRACT NO.
DATE: FEB 2023	SCALE: 1:250 N/A
DRAWING NO. 386001	SHEET: 1 OF 1 REV: 1

WESTBROOK CONSULTING LTD. - 2023-06-15 10:37AM \\WP-5201\deliberate\CA\PROJECTS\3860\_3469\_Hopwood\_PVC\Drawings\386001.dwg

## 1.1 OBJECTIVES

The purpose of this EA is to assess the current terrestrial and riparian environments onsite, identifying terrestrial and aquatic habitat, sensitive ecosystems, and wildlife habitat, including wildlife trees, nests, and any other wildlife features. This EA also identifies the presence of threatened or endangered species on or around the Site, which includes a 2-kilometre (km) buffer around the Site boundaries. As part of the EA, Corvidae completed a detailed field assessment to document biophysical features, habitat and verify available ecosystem inventory data.

From this information potential impacts have been determined and mitigations provided to protect the natural environment, its ecosystems and associated biological diversity. This report and planning meet the environmental requirements in the City of Colwood Official Community Plan, zoning by-laws and addresses provincial and federal laws.

## 1.2 REGULATORY FRAMEWORK

This environmental assessment is designed to comply with the provisions set out in the City of Colwood Official Community Plan (OCP) for development permit areas and for compliance with the provisions for environmental protection contained in the following relevant legislation:

### Municipal

- City of Colwood OCP, Bylaw No. 1700 (City of Colwood 2018)

#### Natural Hazards DPA

##### *Objectives*

- Protect lives and property from hazardous conditions such as landslides and erosion by avoiding development on unstable or hazardous areas.
- Protect people and development from flooding and erosional processes associated with extreme weather events and potential sea level rise in ways that do not lead to hardening of shorelines and loss of environmental and recreational values.
- Protect lives and property from interface wildfire.

#### *Steeply Sloped Areas (OCP Section 23.1)*

- Development on lands with slopes greater than 30% must be avoided. Development may be considered on slopes greater than 30% only where it can be demonstrated that the proposed development will not create geotechnical, ecological, or visual impacts, can be sensitively integrated with terrain, and presents no hazards to people or property.
- Grading or alteration of key topographic features such as knolls, ridgelines, rocky outcrops, cliffs, and ravines must be avoided.

#### Environmental Protection DPA

##### *Objectives*

- Protect wildlife habitat and corridors, and environmentally sensitive areas on hillsides.



- Identify significant features prior to development and protect hillside character and natural features.
- Conserve unique natural features such as landforms, rock outcrops, mature trees and vegetation, hilltops, and ridge lines.
- Minimize blasting and re-contouring of hillsides.

#### *Hillsides (OCP Section 22.1)*

- Take advantage of topography and minimize disruption of rock outcroppings, sensitive ecosystems, mature trees, and culturally significant features.
- Open space and corridors between development areas or lots should be retained to provide continuous habitat linkages within the site and surrounding area. Significant features such as rock outcrops, streams, cliffs, and stands of trees should be incorporated into the open space and corridors as much as possible.

The guiding principle for the use of Development Permits is found within the *Local Government Act*. Development Permit Areas can be designated for purposes such as, but not limited to: protecting, enhancing and restoring the biodiversity and ecological values and functions of environmentally sensitive areas; fostering compatibility between development, existing land uses and environmentally sensitive areas; maintaining connectivity between sensitive ecosystems; and protecting water quality and quantity.

#### **Provincial**

- *Wildlife Act* (1996)
- Invasive Species Council of BC
- *Weed Control Act* (1996, current as of October 2016)

#### **Federal**

- *Migratory Birds Convention Act* (1994)
- *Species at Risk Act* (SARA) (2002)

### **1.3 DEVELOPMENT PERMIT AREAS**

As per Figure 19 of the City of Colwood OCP, the Site occurs within the Natural Hazards Development Permit Area (DPA) (Figure 3). The objectives of this DPA include the protection of lives and property from hazardous conditions, potential erosion and flooding associated with extreme weather events and sea-level rise, and wildfire. Boundaries of this DPA on the property are shown in Figure 3.

Commentaries regarding development requirements to ensure human safety and slope stability within the Natural Hazards DPA on the property are outside of the scope of this EA (which focuses on biophysical attributes). A geotechnical evaluation prepared by a registered geotechnical professional is being completed to address that the site is safe for its intended use.



As per Figure 18 of the City of Colwood OCP, the Site also occurs within the Environmental Protection DPA (Hillside). The objectives of this DPA include the protection of wildlife habitat and corridors, and environmentally sensitive areas on hillsides, identifying significant features prior to development, and protecting hillside character and natural features. Other objectives include conservation of unique natural features such as landforms, rock outcrops, mature trees and vegetation, hilltops, and ridge lines, and minimizing blasting and re-contouring of hillsides.





City of Colwood, Maxar, Microsoft

**Development Permit Areas**

Environmental Protection DPA (Hillside)
  Natural Hazards DPA (Steeply Sloped Areas)
  Project Boundary

0      5      10      20  
 ─────────── Meters

Project: 3469 Hopwood Place | Sources: Capital Regional District, City of Colwood



Rev. #	Date
0	July 7, 2023

Corvidae Project No.  
COR-2023-073

**Figure 3**

## 2 SCOPE OF WORK

Corvidae completed an environmental assessment for the Site and documented the ecological features. Background information was reviewed, including applicable databases. The following features were documented and provided in this report:

- Areas of sensitivity, including mapped potential sharp-tailed snake habitat.
- Areas of habitat and biodiversity values
- Plant communities and plant species on site.
- Potential wildlife presence and wildlife habitat.
- Soil types and terrain.

## 3 METHODS

### 3.1 DESKTOP REVIEW

Baseline biophysical conditions were compiled by reviewing the best available data and information including existing reports for the area and conducting searches of online provincial and federal databases:

- BC Conservation Data Centre (BC CDC 2023a and 2023b).
- BC HabitatWizard (Province of BC 2023).
- Aerial photographs of the Site (Google Earth 2023).
- CRD mapping system and database (CRD 2023).
- City of Colwood GIS Mapping (City of Colwood n.d.)
- Colwood Official Community Plan Bylaw No. 1700 (City of Colwood 2018).

### 3.2 FIELD ASSESSMENT

A field assessment of the Site was completed by a Qualified Environmental Professional (QEP) from Corvidae. The assessment included characterization of vegetation and habitat types, wildlife sign and species observations, wildlife habitat, and assessed the current conditions of the Site.



## 4 ENVIRONMENTAL SITE ASSESSMENT

Corvidae completed a site visit on June 23, 2023. Site photographs are included as Appendix A.

### 4.1 LAND USE

The site is currently vacant, and evidence of previous disturbance is abundant throughout (i.e., vegetation clearing and ground disturbance). Land use in the surrounding areas is primarily residential. The Site is bound by residential properties to the north and west, by Veterans Memorial Parkway to the east, and by an empty lot (zoned CD22) to the south.

### 4.2 CLIMATE AND BIOGEOCLIMATIC ZONE

The project is located within the Coastal Douglas-fir (CDF) biogeoclimatic zone, specifically in the Moist Maritime Coastal Douglas-fir Subzone (CDFmm) (BC CDC 2023b). The CDFmm occurs at low elevations (<150 m) along southeast Vancouver Island, the southern Gulf Islands, and part of the Sunshine Coast. The CDFmm has the mildest climate in Canada. This subzone has a long growing season with warm, dry summers and mild, wet winters.

### 4.3 TERRAIN AND SOILS

Soils in the CDF biogeoclimatic zone are generally derived from morainal, colluvial, and marine deposits, and are typically Brunisols, grading with increased precipitation to Humo-Ferric Podzols (Nuszdorfer et al. 1991). Soils on the site are described as rapidly drained, Orthic Dystric Brunisols (60%) underlain by undifferentiated bedrock (20%) and well-drained Duric Dystric Brunisols (20%) (SIFT 2018). The terrain onsite generally slopes from the northwest to the southeast. Steep slopes are present to the south and the east.

### 4.4 SURFACE WATER

Surface water features (e.g., watercourses, wetlands, etc.) were not detected during the field assessment on the site or within 30 metres of the site boundaries.

### 4.5 VEGETATION

Due to prior site clearing, vegetation is limited to grasses, young conifers, and non-native and invasive vegetation species. Native shrub cover was generally lacking on the site and the moss layer was absent. Large patches of scotch broom have invaded the site surfaces and are interspersed with bare areas of exposed rock. Young, native conifers remain along the steep slopes to the east leading down to Veterans Memorial Parkway and near the southwest corner.

Three invasive plant species were observed on the Site: Himalayan blackberry, scotch broom, and tansy ragwort. These are listed as "Control" species as per the Coastal Invasive Species Committee (2023). It is recommended that efforts to control these species are focused within high value conservation areas and that the use of Biological Control, if available, is utilized on a landscape scale. Measures to remove and prevent invasive species are recommended and discussed in Section 6 of this report. All vegetation species noted during the June 23, 2023, field visit are included below in Table 1.



**Table 1. Plant species observed on or near the site during the June 23, 2023, field visit.**

Common Name	Scientific Name	BC Provincial Status <sup>1</sup>	SARA Schedule 1 Status <sup>2</sup>
Arbutus	<i>Arbutus menziesii</i>	Yellow	--
California poppy	<i>Eschscholzia californica</i>	Exotic	--
Douglas-fir	<i>Pseudotsuga menziesii</i>	Yellow	--
Dull Oregon-grape	<i>Mahonia nervosa</i>	Yellow	--
Grand fir	<i>Abies grandis</i>	Yellow	--
Grass species	<i>Poa</i> sp.	--	--
Himalayan blackberry	<i>Rubus armeniacus</i>	<b>Invasive</b> ; Exotic	--
Oceanspray	<i>Holodiscus discolor</i>	Yellow	--
Salal	<i>Gaultheria shallon</i>	Yellow	--
Salmonberry	<i>Rubus spectabilis</i>	Yellow	--
Scotch broom	<i>Cytisus scoparius</i>	<b>Invasive</b> ; Exotic	--
Sword fern	<i>Polystichum munitum</i>	Yellow	--
Tansy ragwort	<i>Jacobaea vulgaris</i>	<b>Invasive</b> ; Exotic	--
Trailing blackberry	<i>Rubus ursinus</i>	Yellow	--
Western redcedar	<i>Thuja plicata</i>	Yellow	--

<sup>1</sup> BC CDC 2023a<sup>2</sup> Government of Canada 2023

## 4.6 WILDLIFE

Remaining vegetation on the Site, including shrubs and young conifers, may provide nesting habitat for migratory songbirds and year-round resident species (e.g., Anna's hummingbird). There is no suitable nesting or roosting habitat for raptors and owls (i.e., no mature trees or wildlife trees). The site may also be used by deer; however, none were seen during the assessment. Potential for reptile use on the site, particularly in areas of south-facing, exposed rock is considered likely based on observations of European wall lizard during the site assessment. All species detected during the site assessment are included in Table 2.

The northwestern extent of the Site is overlapped by an area of mapped potential sharp-tailed snake habitat (CRD 2021) (Figure 4). This area was previously determined by desktop mapping. Sharp-tailed snake is a red-listed species in BC and is designated as Endangered under Schedule 1 of SARA. Suitable habitat for Sharp-tailed Snake must provide sites for thermoregulation, egg laying, incubation, and inactive phases (overwintering/hibernation and summer inactivity/aestivation) as well as foraging opportunities. Sharp-tailed Snakes are generally found within open canopy forest, dominated by Douglas-fir, arbutus, and/or Garry oak, which provides the mosaic of shaded/cool/moist and open/warm patches required for the snakes to carry out their lifecycle. Critical habitat is identified whenever sparsely forested or treeless rocky openings (~10 m diameter and greater) with warm (southerly) aspects are found. Open habitats must be surrounded by open canopy forest habitat that support prey populations (slugs) and provide opportunities for thermoregulation. In both open habitats and adjacent forest, 3-dimensional features composed of rock or coarse woody debris that provide microhabitats must be present (Environment and Climate Change Canada [ECCC] 2020). No federally designated critical habitat is mapped in the area (ECCC 2020).





Potential for sharp-tailed snake on the Site is considered low due to the absence of suitable habitat. Prior disturbances on the site have likely negatively impacted the potential for this species to occur. Previously forested habitat in the adjacent site to the south has also been cleared, further reducing the likelihood of sharp-tailed snake occupying the site.

**Table 2. Wildlife Species observed on site during the June 23, 2023, field visit.**

Common Name	Scientific Name	BC Provincial Status <sup>1</sup>	SARA Schedule 1 Status <sup>2</sup>
Anna's hummingbird	<i>Calypte anna</i>	Yellow	--
American robin	<i>Turdus migratorius</i>	Yellow	--
European wall lizard	<i>Podarcis muralis</i>	Exotic	--

<sup>1</sup> BC CDC 2023a

<sup>2</sup> Government of Canada 2023

## 4.7 SPECIES AT RISK

A query of the BC CDC iMap tool yielded occurrences of 3 species and 3 ecosystems at risk within a two-kilometer radius of the Site, as well as one masked occurrence (BC CDC 2023b) (Table 3).

The Site engages a mapped polygon for the sensitive ecosystem classified as a Douglas-fir – Oregon-grape ecological community within the CDFmm (Figure 5). This occurrence is mapped by the BC Conservation Data Centre and is a red-listed community that is critically imperiled (Province of BC 2023).

Mature, intact forests within this ecological community are characterized by mature Douglas-fir, western redcedar, arbutus and bigleaf maple trees ranging from 80 to 100 years-old. The understory has a well-developed mix of shrubs, including dull Oregon-grape, salal, red huckleberry, oceanspray and baldhip rose. The forest floor has scattered sword fern and hairy honeysuckle with an almost continuous moss carpet dominated by step moss, Oregon beaked-moss and electrified cat's-tail moss. Several dead or dying mature trees are typically present that provide habitat for nesting birds and small mammals (BC CDC 2012). The Site has previously been cleared and thus this ecosystem is not present. No other species or ecosystems listed in Table 3 were detected on the Site, nor was suitable habitat identified on the Site for the species mentioned.

**Table 3. Species at risk that may occur in the vicinity of 3496 Hopwood Place, Colwood, BC.**

Common Name	Scientific Name	BC Provincial Status <sup>1</sup>	SARA Schedule 1 Status <sup>2</sup>
<b>Species</b>			
Northern Red-legged Frog	<i>Rana aurora</i>	Blue	Special Concern
Slimleaf Onion	<i>Allium amplexans</i>	Blue	n/a
Common bluecup	<i>Githopsis specularioides</i>	Blue	n/a
<b>Ecosystems</b>			
Douglas-fir / dull Oregon-grape	<i>Pseudotsuga menziesii</i> / <i>Mahonia nervosa</i>	Red	n/a
Grand fir / three-leaved foamflower	<i>Abies grandis</i> / <i>Tiarella trifoliata</i>	Red	n/a
Grand fir / dull Oregon-grape	<i>Abies grandis</i> / <i>Mahonia nervosa</i>	Red	n/a

<sup>1</sup> BC CDC 2023a

<sup>2</sup> Government of Canada 2023



## CRITICAL HABITAT

Mapped critical habitat for Western Painted Turtle (Pacific Coast population) (*Chrysemys picta bellii*) overlaps the Site (Figure 5). Western Painted Turtles are a provincially red listed (critically imperiled) species and are listed as endangered under the federal *Species at Risk Act*. This species is highly aquatic but does require terrestrial habitat for nesting, basking, and movement (Environment and Climate Change Canada 2018). Nesting habitats are on land adjacent to aquatic foraging habitat, usually within 200 m of the water body, typically on gentle south-facing slopes. There are no aquatic features on the property that would support the life history functions of this species and no nesting habitat was identified during the site assessment. The probability of Western Painted Turtle occurring on the Site is considered low.





Capital Regional District

Site Location and Mapped Potential Sharp-tailed Snake Habitat

- Project Boundary
- Potential Sharp-tailed Snake Habitat

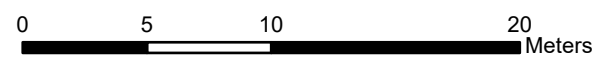

Project: 3469 Hopwood Place | Sources: Capital Regional District



Corvidae Project No.  
COR-2023-073

Rev. #	Date
0	July 7, 2023

**Figure 4**



Species at Risk within 2 km

- |                                    |   |                        |
|------------------------------------|---|------------------------|
| Project Boundary                   | <b>Critical Habitat</b>                         | <b>Species at Risk</b> |
| 2 km area around property boundary | Deltoid Balsamroot                              | Ecological Community   |
|                                    | Macoun's Meadowfoam                             | Invertebrate Animal    |
|                                    | Phantom Orchid                                  | Vascular Plant         |
|                                    | Western Painted Turtle Pacific Coast population | Vertebrate Animal      |

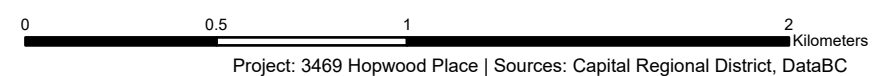

**CORVIDAE**  
ENVIRONMENTAL CONSULTING INC

Corvidae Project No.  
COR-2023-073

Rev. #	Date
0	July 7, 2023
<b>Figure 5</b>	

Capital Regional District

## 5 POTENTIAL ENVIRONMENTAL EFFECTS

The potential impacts of future development of the Site on the environment are:

- Further spread of invasive plant species.
- Change in wildlife habitat availability and wildlife mortality risk.
- Sediment movement in the project area.

The residual environmental impacts of the activities on the Site will be reduced by the implementation of the mitigation and restoration measures recommended in Section 6 of this report.

### INVASIVE SPECIES

Invasive plants are particularly adept at colonizing degraded plant communities and disturbed soils. Invasive plants establish readily in disturbed areas as they have a wide ecological tolerance and grow and propagate quickly. The effects of invasive plant establishment may be the reduction or displacement of native species by capturing resources and occupying habitats.

### WILDLIFE AND WILDLIFE HABITAT

Loss and alteration of vegetation can result in the loss of habitat for wildlife species. Rock blasting and site grading can also disturb wildlife or cause mortality. Noise from site preparation and construction may temporarily disturb and displace wildlife residing or passing through the Site.

### EROSION AND SEDIMENT

Removal of vegetation during site preparation and construction exposes soils to erosion and can result in the movement of sediment on the Site. Damage or degradation of soil surfaces during site preparation and construction can include loss of soil structure, increased erosion, and soil compaction.

## 6 RECOMMENDED ENVIRONMENTAL PROTECTION MEASURES

The mitigation measures provided in this report are designed to protect sensitive ecosystems and were developed in accordance with:

- The City of Colwood OCP (City of Colwood 2018),
- Procedures for Mitigating Impacts on Environmental Values (Environmental Mitigation Procedures) (BC Ministry of Environment [MOE] 2014a),
- Develop with Care 2014: Environmental Guidelines for Urban and Rural Land Development in British Columbia (Government of BC 2014), and
- Environmental Best Management Practices for Urban and Rural Land Development in British Columbia (BC Ministry of Water, Land and Air Protection 2004).



The mitigation measures identified below are expected to reduce potential environmental impacts when applied during subdivision site preparation and future development and building activities on the proposed lots.

## VEGETATION

Retention of native vegetation is recommended wherever feasible. Tree protection fencing should be installed to protect the drip and root zones of any retained trees near active construction areas.

It is recommended that areas disturbed by site preparation and project construction activities that are not part of a permanent road or residential footprint be replanted with native vegetation. Enhancement of the proposed lots is also recommended through the removal of invasive species and subsequent application of a native seed mix and installation of native plants. Table 4 details native plant species that are suitable for the area. Recommended plant density following invasive removal is 1 to 2 m<sup>2</sup> for shrubs and 3 m<sup>2</sup> for trees.

The following are recommended species to include in a native seed mix blend for application within disturbed and landscaped areas: *Festuca occidentalis* (western fescue), *Melica subulata* (Alaska oniongrass) *Elymus glaucus* (blue wildrye), *Bromus carinatus* (California brome), *Bromus vulgaris* (Columbia brome), *Festuca occidentalis* (western fescue) and *Sanicula crassicaulis* (pacific sanicle).

The purpose of using native species is to reduce irrigation maintenance in the future. The optimal time for revegetation is in the fall, prior to the wet winter season. However, planting at any time of the year (with irrigation as needed) is acceptable to prevent invasive species.

**Table 4. Recommended native vegetation species options for future enhancement.**

Common Name	Species
Douglas-fir	<i>Pseudotsuga menziesii</i>
Arbutus	<i>Arbutus menziesii</i>
Oceanspray	<i>Holodiscus discolor</i>
Rose species	<i>Rosa nutkana / gymnocarpa</i>
Salal	<i>Gaultheria shallon</i>
Dull Oregon-grape	<i>Mahonia nervosa</i>
Great camas	<i>Camassia leichtlinii</i>

## INVASIVE SPECIES

Any invasive species encountered on the Site will require removal. Invasive species should be removed using the most appropriate methods, at the correct time of year, and plant material must be disposed of correctly to avoid re-establishment or spread. Following removal, re-seed bare soil with desirable, competing vegetation. Details of removal methods for the invasive species onsite are provided below in Table 5.



**Table 5. Removal and disposal methods for invasive species**

Species	Removal Method	Removal Timing	Plant Disposal
Himalayan blackberry	Can be removed by pulling or cutting the canes from the ground. If possible, dig out the roots, paying careful attention not to damage nearby vegetation.	Removal should occur in the spring and early summer before they produce berries as canes that are cut as the plant is producing flowers are least likely to re-sprout.	Burned or bagged and disposed of properly in a landfill. Do not compost.
Scotch broom	Avoid disturbing the soil which can stimulate dormant broom seeds to sprout. Small broom plants can be pulled easily from the ground by hand without disturbing the soil. Larger plants should be cut below the root crown using loppers or a pruning saw.	Scotch broom removal should occur mid-April through early June, when in flower and before its seed pods begin to open.	Bagged and disposed of properly in a landfill or burning. Do not 'recycle' garden debris or compost.
Tansy ragwort	Tansy ragweed can be controlled by cutting (prior to flowering) and hand pulling if the roots are removed. Gloves and other protective clothing should be worn to prevent skin irritation.	Hand pull before flowering to eliminate seed production.	If plants are cut or pulled prior to flowering, the plant material can be left on the site to decompose. If plants are cut post flowering, all plant parts, including flower heads, should be bagged and disposed of properly in a landfill.

Mitigation measures to control and minimize the spread of invasive weeds on the site include:

- Clean all machinery before arrival onto the site to ensure that more weed seeds and other propagules (e.g., pieces of root) are not brought into the project area.
- If fill or topsoil is imported from external areas, ensure that it is from a weed-free source.

Any soil should not be left exposed until landscaping. Disturbed areas should be seeded with fast growing vegetation such as a mix with a native clover or seed mix to compete with weed species, fix nitrogen and provide soil stabilization right after clearing.

## WILDLIFE AND WILDLIFE HABITAT

Mitigation measures to minimize impacts of the proposed subdivision and subsequent residential development on wildlife and wildlife habitat include:

- Vegetation clearing should be completed outside of the migratory bird window (prior to March 15<sup>th</sup> or after August 31<sup>st</sup>; Government of Canada 2021). If vegetation clearing is scheduled within the sensitive time period for breeding birds, a QEP should conduct nest search surveys a maximum of 2-3 days prior to the start of activities. If an active nest is discovered during nest searches or clearing activities, the nest will be subject to site-specific mitigation measures (e.g., protective buffer around the nest or unobtrusive monitoring) until the young have naturally fledged/left the area. Multiple nest sweeps may be required. Nest search areas include both vegetation and any onsite, man-made structures that are scheduled for removal.



- Avoid additional removal of established native trees or shrubs, where practical, except for identified danger trees that cannot be avoided.
- Maintain natural areas where possible to promote reptile habitat by leaving natural cover like leaf litter, fallen logs, bark, and rocks. Placement of additional rocks or logs in sunny areas is also recommended for resident reptiles, and to add habitat complexity.

## **EROSION AND SEDIMENT CONTROL**

The primary focus of erosion and sediment control planning is erosion control; if there is no erosion then there is no sediment. Erosion control is far more cost effective to implement and manage than sediment control.

Mitigation options to minimize the potential effects of erosion and sediment movement on the natural environment include:

- No soil should be left exposed for more than one growing season. Disturbed areas should be seeded with fast growing vegetation such as a mix with a native clover or seed mix to compete with weed species, fix nitrogen and provide soil stabilization right after vegetation removal.
- If erosion or sediment movement is observed during site preparation activities, silt fencing or straw wattles should be installed to direct sediment to a holding area or vegetated area to settle.
- Regularly inspect and maintain Erosion and Sediment Control measures for the duration of the project.

Measures must also be taken to prevent the risk of hazardous materials and contaminant spills, including oil, gas, and hydraulic fluid during construction. It is recommended that a large, labeled, mobile spill kit is kept onsite during construction works and that all construction equipment is kept in good working order without leaks.





## 7 CONCLUSION

The potential environmental impacts of the proposed subdivision at 3469 Hopwood Place have been presented in this report. As development plans progress, implementation of the mitigation and restoration measures recommended in this report, including native plant installation and invasive species removal and the implementation of erosion and sediment controls during construction, will minimize the impacts of the proposed subdivision on the environment. All works are to be completed in compliance with the Migratory Bird window.

Report Prepared By:

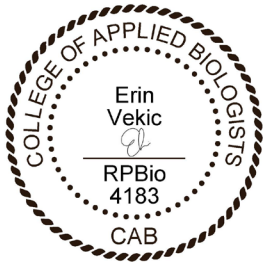

Erin Vekic, R.P.Bio, M.Sc.  
Corvidae Environmental Consulting Inc.  
604-617-5024



## 8 REFERENCES

- British Columbia Conservation Data Centre (CDC). 2023a. BC Species and Ecosystems Explorer. B.C. Ministry of Environment. Victoria, B.C. Available: <http://a100.gov.bc.ca/pub/eswp/>. Accessed: July 2023.
- British Columbia Conservation Data Centre (CDC). 2023b. CDC iMap [web application]. Available at: <http://maps.gov.bc.ca/ess/sv/cdc/>. Accessed: July 2023.
- B.C. Conservation Data Centre. 2012. Ecological Community Summary: *Pseudotsuga menziesii* / *Mahonia nervosa*. B.C. Minist. of Environment. Available: <https://a100.gov.bc.ca/pub/eswp/>.
- B.C. Conservation Data Centre. 2014. Occurrence Report Summary, Shape ID: 55776, Douglas-fir / dull Oregon-grape. B.C. Ministry of Environment. Available: <http://maps.gov.bc.ca/ess/hm/cdc/>.
- British Columbia Ministry of Environment (MOE). 2014a. Procedures for Mitigating Impacts on Environmental Values (Environmental Mitigation Procedures) Version 1.0. Available at: [https://www2.gov.bc.ca/assets/gov/environment/natural-resource-policy-legislation/environmental-mitigation-policy/em\\_procedures\\_may27\\_2014.pdf](https://www2.gov.bc.ca/assets/gov/environment/natural-resource-policy-legislation/environmental-mitigation-policy/em_procedures_may27_2014.pdf).
- British Columbia Ministry of Environment (MOE). 2014b. Develop with Care 2014: Environmental Guidelines for Urban and Rural Land Development in British Columbia. Available at: <https://www2.gov.bc.ca/gov/content/environment/natural-resourcestewardship/naturalresource-standards-and-guidance/best-managementpractices/develop-with-care>.
- British Columbia Ministry of Environment. 2004. Environmental Best Management Practices for Urban and Rural Land Development. Available at: [https://www.env.gov.bc.ca/wld/documents/bmp/urban\\_ebmp/urban\\_ebmp.html](https://www.env.gov.bc.ca/wld/documents/bmp/urban_ebmp/urban_ebmp.html).
- British Columbia Soil Information Finder Tool (SIFT). 2018. Interactive Mapping Application. Available at: <https://governmentofbc.maps.arcgis.com/apps/MapSeries/index.html?appid=cc25e43525c5471ca7b13d639bbcd7aa>.
- City of Colwood. 2018. Official Community Plan Bylaw 1700. Available at: <https://colwood.civicweb.net/document/131567/>. Accessed: June 2023.
- City of Colwood. n.d. City of Colwood GIS Map. Available at: <http://colwood.maps.arcgis.com/apps/webappviewer/index.html?id=84a08451d8c94076adde5e21d2cbc84e>. Accessed: June 2023.
- Coastal Invasive Species Committee (Coastal ISC). 2022. Coastal ISC Priority Invasive Plants. Available at: <https://www.coastalisc.com/priority-invasive-plants/>. Accessed July 2023.
- Capital Regional District. 2021. CRD Regional Map. Available at: <https://maps.crd.bc.ca/Html5Viewer/?viewer=public>. Accessed: June 2023.
- Environment and Climate Change Canada. 2018. Recovery Strategy for the Western Painted Turtle (*Chrysemys picta bellii*) Pacific Coast population in Canada [Proposed]. *Species at Risk Act Recovery Strategy Series*. Environment and Climate Change Canada, Ottawa. 2 parts, 31 pp. + 59 pp.
- Environment and Climate Change Canada. 2020. Recovery Strategy for the Sharp-tailed Snake (*Contia tenuis*) in Canada. *Species at Risk Act Recovery Strategy Series*. Environment and Climate Change Canada, Ottawa. 2 parts, 17 pp. + 42 pp



Government of Canada. 2023a. Species at Risk Public Registry. Available at:  
<https://www.canada.ca/en/environment-climate-change/services/species-risk-publicregistry.html>. Accessed: July 2023.

Government of Canada. 2021. General nesting periods of migratory birds. Available at:  
<https://www.canada.ca/en/environment-climate-change/services/avoiding-harm-migratory-birds/general-nesting-periods/nesting-periods.html>.

Nuszdorfer., F.C., K. Klinka, and D.A. Demarachi. 1991. Coastal Douglas-fir Zone. In Ecosystems of British Columbia. D. Meidinger and J. Available at:  
<https://www.for.gov.bc.ca/hfd/pubs/docs/srs/Srs06/chap5.pdf>. B.C. Ministry of Forestry, Victoria, BC. Special Report Series 6. Pp 82 - 93.

Province of British Columbia. 2023. HabitatWizard. Available at:  
<http://maps.gov.bc.ca/ess/hm/habwiz/>. Accessed: June 2023.



## APPENDIX A – SITE PHOTOGRAPHS

**Photo 1. Northwest view of site entrance and adjacent residential development. June 23, 2023.**



**Photo 2. Southeast view of Site and existing vegetation. June 23, 2023**



**Photo 3. Northwest view looking back upslope into the Site. June 23, 2023.**



**Photo 4. North view of exposed, disturbed rock. June 23, 2023.**



**Photo 5. Scotch broom infestation, looking east. June 23, 2023**



**Photo 6. South view of adjacent cleared lot. June 23, 2023.**



**Photo 7. Vegetation at top of slope along the eastern property edge near Veterans Memorial Parkway, looking southeast. June 23, 2023.**



**Photo 8. View of Veterans Memorial Parkway from eastern site extent, looking northeast. June 23, 2023.**





**MGE Services Inc.**

EGBC Permit to Practice No. 1003085

740 Cowper Street, Victoria, BC V9A 2E9  
250-661-8335

MGEservices@shaw.ca

## Schedule 2

June 7, 2023

File: 23C-023

Cactus Developments Ltd.  
4529 Parry Cross Road  
Victoria, BC V9C 3W1

Attention: Mr. Rex Coburn

**RE: Proposed 2-Lot Subdivision – 3469 Hopwood Place, Colwood  
Preliminary Geotechnical Assessment**

### 1.0 INTRODUCTION

As requested by Cactus Developments Ltd. (Client), MGE Services Inc. (MGE) has carried out a preliminary geotechnical assessment for a proposed two-lot subdivision at the above-referenced site. The subject site consists of a single lot that was developed as part of the Resolution Way subdivision and has remained as a vacant lot for more than ten years. It is understood that wood-framed, single family houses will be constructed on the new lots. This preliminary geotechnical review was conducted in accordance with our March 6, 2023 contract, which was approved by the Client on March 8, 2023.

The proposed development site is located at the end of the Hopwood Place cul-de-sac and will be developed with a common driveway that will access the two lots. The two new lots are labelled Lots A and B, with Lot A located on the north side of Lot B, as shown on the Site Plan dated Feb 2023 that was prepared by Westbrook Consulting Ltd. (Westbrook). It is understood that grading of the project will be carried out to create approximately level lots, which will likely require retaining wall construction along the south and east sides of Lot B.

### 2.0 SITE CONDITIONS

The proposed site consists of an undeveloped property from the Resolution Way subdivision. Review of geology mapping indicates that the area is underlain by dense tills of the Vashon Till deposit, with outcrops of intact bedrock of the Wark Gneiss formation. Both the till and bedrock are considered competent bearing for the proposed development.

A site walkover was performed with the Client on March 8, 2023, with a follow-up review to confirm grading on May 31, 2023. There are several stockpiles of miscellaneous materials that have become overgrown with vegetation in the ten plus years that the site has been vacant. The existing grade of the site slopes down to the south and east with an approx. 2.5 to 4m grade change between the south side of Lot B to the north side of Lot A. The undulating bedrock surface is exposed along the majority of the southern property line, which will provide suitable bearing for retaining wall construction, which is further discussed herein.





## MGE Services Inc.

EGBC Permit to Practice No. 1003085

740 Cowper Street, Victoria, BC V9A 2E9  
250-661-8335

MGEservices@shaw.ca

June 7, 2023  
File: 23C-023

### 3.0 DISCUSSION AND RECOMMENDATIONS

Based on our preliminary geotechnical review of the site, development of two single family houses is considered geotechnically suitable provided the recommendations provided herein are followed. It is recommended that the two building sites and associated infrastructure be excavated to expose dense till and/or intact bedrock. Following review and approval of the subgrade soils by MGE, it will be necessary to prepare site by placement of structural fills to achieve the design elevation grade of the foundations. Structural fills should be placed to extend outside the building footprint by at least the thickness of the structural fill, ie. a 1H:1V splay.

Placement and compaction of structural fill should be carried out in lifts that maximize the effectiveness of the compaction equipment based on the type of material. The preferred material for structural fill is maximum 300mm diameter, well-graded shotrock. Compaction of shotrock fills should be carried out in maximum 450mm thickness lifts, with a minimum six passes per lift using a steel drum, vibratory roller. MGE should be contacted when structural filling is ongoing to carry out periodic review of the fill placement and compaction procedure.

Foundation design on the structural fills placed over dense tills and/or bedrock can use 150 kPa as the bearing pressure for foundation footings. Further review of the house sites will need to be carried out when foundation plans are finalized for each of the two new lots.

Retaining wall construction is proposed as part of the project to provide support for fill placement to achieve the design grade. It is considered appropriate to construct the wall(s) as dry stack boulder walls with the maximum height of a single boulder wall will be limited to 1.2m, with the face batter observed to be no steeper than ½H:1V. Where the grade change is greater than 1.2m, the wall will need to be tiered. In order to maintain a 1H:1V splay between tiers of the retaining wall, a horizontal distance of 1.2m is required from the toe of a lower tier to the toe of the next tier above. The boulders are to be suitably interlocked and placed with the long axis of the boulder extending back into the wall. This retaining wall construction is considered to be in accordance with our geotechnical recommendations and meets the City of Colwood bylaw requirements.

It is understood that the development is proposed to infiltrate some of the stormwater into the shotrock structural fills at the rear of each lot. Due to the free-draining nature of shotrock fill and the topography of the site sloping down to the southeast, disposal of stormwater is expected to be geotechnically suitable. MGE can provide further assistance to the Civil Engineer as the stormwater management plan is developed.



**MGE Services Inc.**

EGBC Permit to Practice No. 1003085

740 Cowper Street, Victoria, BC V9A 2E9  
250-661-8335

MGEservices@shaw.ca

June 7, 2023  
File: 23C-023

**4.0 CLOSURE**

Based on our site review, the site is geotechnically suitable for the proposed development. The recommendations provided herein should be reviewed by MGE during construction. Periodic field reviews by MGE will be conducted to confirm the intent of the geotechnical recommendations.

This letter has been prepared exclusively for Cactus Developments Ltd. in accordance with the March 6, 2023 contract between MGE and the Client. No third party can rely on this letter, except for the City of Colwood, which is considered to be an authorized user, subject to the terms and conditions under which the work was completed.

We trust this meets your current requirements and ask that you contact the undersigned if there are any questions or concerns.

Yours truly,  
MGE Services Inc.

A handwritten signature in blue ink, appearing to read 'Alec Morse', is written over the signature line.

Per: Alec Morse, P.Eng.



cc: Westbrook Consulting Ltd – Attn: Iva Kvartuc

# Schedule 3

**GENERAL NOTES**

- ALL CONSTRUCTION AND MATERIALS SHALL BE IN ACCORDANCE WITH MAND, LATEST EDITION, AND THE CITY OF COLWOOD STANDARD SPECIFICATIONS AND DRAWINGS UNLESS OTHERWISE NOTED.
- WHEN A CONFLICT BETWEEN THE SPECIFICATIONS ARISES, THE MOST STRINGENT SHALL APPLY.
- OBTAIN A PERMIT TO CONSTRUCT WORKS ON A MUNICIPAL RIGHT OF WAY FROM THE CITY OF COLWOOD. ENGINEERING DEPARTMENT SEVEN WORKING DAYS PRIOR TO THE START OF ANY CONSTRUCTION.
- CONTACT BC HYDRO, TELUS, SHAW CABLE AND FORTISBC GAS THREE WORKING DAYS PRIOR TO THE START OF ANY EXCAVATION.
- EXPOSE ALL EXISTING SERVICES AT CONNECTION AND CROSSING POINTS TWO WORKING DAYS PRIOR STARTING CONSTRUCTION ON ANY SUCH SERVICES. ENSURE ENGINEER HAS CONFIRMED THE HORIZONTAL AND VERTICAL LOCATION.
- BEEL ALL PIPE USING CLASS "B" BEDDING.
- WHERE A TRENCH IS UNDER OR WITHIN 1.0m OF THE EDGE OF A ROAD OR DRIVEWAY, USE PIT RUN GRAVEL BACKFILL FROM THE TOP OF THE PIPE BEDDING TO THE TOP OF THE ROAD, PARKING OR DRIVEWAY SUBGRADE.
- DO NOT START ANY BACKFILL OPERATION UNTIL THE WORKS HAVE BEEN INSPECTED BY THE ENGINEER.
- AFTER CONSTRUCTION, RESTORE WORK AREAS AND ALL EXISTING FEATURES TO THEIR ORIGINAL CONDITION OR BETTER.
- MAINTAIN VEHICULAR AND PEDESTRIAN ACCESS ALONG HOPWOOD PLACE DURING CONSTRUCTION.
- COMPACT TRENCH BACKFILL, ROAD BASE AND DRIVEWAY BASE TO 90% MODIFIED PROCTOR DENSITY.
- ADJUST ALL PROPOSED AND EXISTING APPURTENANCES TO MEET THE FINAL DESIGN GRADES.
- ENSURE THAT ALL SERVICES TO THE EXISTING HOUSES REMAIN USABLE DURING CONSTRUCTION.
- CONSTRUCT SEWER, DRAIN, WATER AND ROADS WITHIN PRIVATE PROPERTY IN ACCORDANCE WITH THE BC PLUMBING CODE AND BC BUILDING CODE. CONSTRUCTION SHALL BE INSPECTED AND APPROVED BY THE CITY OF COLWOOD INSPECTORS.
- CONTRACTOR TO MAINTAIN A REDLINE MARKUP, ON SITE, OF THE WORKS INSTALLED THAT DAY.

**SEWER AND DRAIN**

- SEWER AND DRAIN SERVICE CONNECTIONS SHALL BE 100P PVC DR28 AT A MINIMUM GRADE OF 2.2% COMPLETE WITH INSPECTION CHAMBERS. CATCH BASIN LEADS SHALL BE 200P PVC DR35 UNLESS OTHERWISE NOTED. IF COVER IS LESS THAN 750mm, USE DUCTILE IRON PIPE.
- SEWER AND DRAIN SERVICE TO ROAD INCLUDING 150mm DIAMETER SHALL BE PVC DR28 AND DECS FOR 200mm DIAMETER AND 150P PVC DR28. APPROVE SHALL BE U.S.A. APPROVE UNLESS OTHERWISE SPECIFIED.
- SEWER AND DRAIN MANHOLES SHALL BE 1050P BARRELS UNLESS OTHERWISE SPECIFIED.
- CONNECT ALL ENCLOSED DRAINAGE TO THE PROPOSED SERVICES CONNECTION. CONTRACTOR TO RECORD THE LOCATION, ELEVATION, PIPE MATERIAL AND SIZE FOR THE RECORD DRAWINGS.
- MAINTAIN INSPECT ALL INSTALLED SANITARY SEWER AND STORM DRAIN MAINS ON PUBLIC AND PRIVATE PROPERTY.

**WATER**

- CONSTRUCTION SHALL NOT PROCEED WITHOUT FIRST OBTAINING CRD WATER SERVICES ACCEPTANCE OF THE DESIGN DRAWINGS AND A CONSTRUCTION PERMIT FROM IHA.
- CONTRACTOR SHALL BE REGISTERED WITH WORK SAFE BC.
- ALL WATERWORKS CONSTRUCTION AND MATERIALS SHALL BE IN ACCORDANCE WITH CRD WATER SERVICES ENGINEERING SPECIFICATIONS AND STANDARD DRAWINGS.
- PROVIDE A MINIMUM 60mm COVER TO A MAXIMUM OF 1.2m COVER FOR WATER MAINS UNLESS APPROVED BY A CRD FORCES ENGINEER.
- MAINTAIN A MINIMUM 50mm HORIZONTAL CLEAR SEPARATION AND 450mm CLEAR VERTICAL SEPARATION BETWEEN WATER SERVICES AND SEWER SERVICES, SANITARY OR STORM/DRAIN, IN SPECIAL CIRCUMSTANCES, WHERE A SANITARY SEWER OR STORM DRAIN SERVICE IS LOWER THAN A WATER SERVICE BY MORE THAN 450mm IN ELEVATION, THE HORIZONTAL OFFSET MAY BE REDUCED TO NO LESS THAN 1.0m EXCEPT WHERE NOTED AND APPROVED BY CRD WATER SERVICES. IHA APPROVAL IS REQUIRED FOR ANY REDUCTION OF THE PROPOSED SEPARATION.
- MAINTAIN A MINIMUM OF 1.0m HORIZONTAL CENTRE TO CENTRE AND 150mm CLEAR VERTICAL SEPARATION BETWEEN WATER SERVICES AND ELECTRICAL, GAS AND TELEPHONE SERVICES EXCEPT WHERE NOTED AND APPROVED BY CRD WATER SERVICES.
- CONTRACTOR SHALL CONDUCT A PROTECTIVE TEST IN ACCORDANCE WITH CRD WATER SERVICES ENGINEERING SPECIFICATIONS AND IN THE PRESENCE OF CRD PERSONNEL.
- NEUTRALIZE CHLORINE SOLUTIONS IN ACCORDANCE WITH MINISTRY OF ENVIRONMENT AND FISHERIES AND OCEANS CANADA REGULATIONS PRIOR TO DISCHARGE TO ANY DRAINAGE COURSE.
- CONTRACTOR SHALL PROVIDE 24 HOUR NOTICE TO CRD WATER SERVICES PRIOR TO PROCEEDING WITH ANY WATERWORKS.

- ① CRD WATER SERVICES SHALL INSTALL THE 25# WATER SERVICE AND WATER TO THE PROPERTY LINE AT THE DEVELOPER'S EXPENSE.
- CRD WATER SERVICES SHALL MAKE ALL CONNECTIONS TO EXISTING WATER MAINS AT DEVELOPER'S EXPENSE. CONTRACTOR SHALL PROVIDE 48 HOURS NOTICE TO CRD WATER SERVICES FOR WORK REQUIRED BY CRD WATER SERVICES FORCES.
- WHERE PRACTICAL, SERVICE LINES AND METER BOXES SHALL BE INSTALLED TO FINISHED GRADE, OUTSIDE OF DRIVEWAYS OR PAVED AREAS.
- ANY TEMPORARY OR PERMANENT CONNECTION TO THE JUAN DE FUCA WATER DISTRIBUTION SYSTEM OR THE CRD SUPPLY SYSTEM SHALL BE PERFORMED BY CRD WATER SERVICES PERSONNEL ONLY.

**ROAD**

- CONSTRUCT ALL ROADWAYS AND CUL DE SACS IN ACCORDANCE WITH THE CITY OF COLWOOD STANDARD SPECIFICATIONS AND AS SHOWN ON THE TYPICAL SECTION AND DETAIL DRAWINGS.
- CONTRACTOR TO ENSURE ALL MONUMENTS ARE NOT DISTURBED DURING CONSTRUCTION. ANY MONUMENTS IN DANGER OF DISTURBANCE ARE SHALL BE REFERENCED BY AND, IF DISTURBED, BE REPLACED BY A B.C.L.S. AT THE CONTRACTOR'S EXPENSE.

**HYDRO, TELEPHONE, CABLE, STREET LIGHTING AND GAS**

- CONTACT "B.C. ONE CALL AT 1-800-474-6886 AND "DIG SHAW" AT DISHWACCA A MINIMUM OF THREE WORKING DAYS PRIOR TO ANY CONSTRUCTION.
- LOTS SHALL BE SERVICED UNDERGROUND.
- BC HYDRO, TELUS, SHAW CABLE AND FORTISBC FACILITIES ARE SHOWN SCHEMATICALLY ON THIS DRAWING. REFER TO UTILITY COMPANY DRAWINGS FOR CONSTRUCTION DETAILS.
- CONSTRUCT UNDERGROUND HYDRO, TELEPHONE AND CABLEWORKS AS SPECIFIED AND IN ACCORDANCE WITH BC HYDRO, TELUS AND SHAW CABLE STANDARD SPECIFICATIONS AND DRAWINGS.
- IF GAS IS REQUIRED, THE DEVELOPER IS TO CONTACT FORTISBC AT 1-888-224-2710 A MINIMUM OF 90 DAYS PRIOR TO INSTALL. FORTISBC SHALL INSTALL GAS SERVICE TO THE PROPERTY LINE.

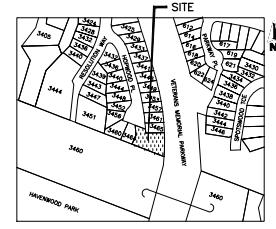
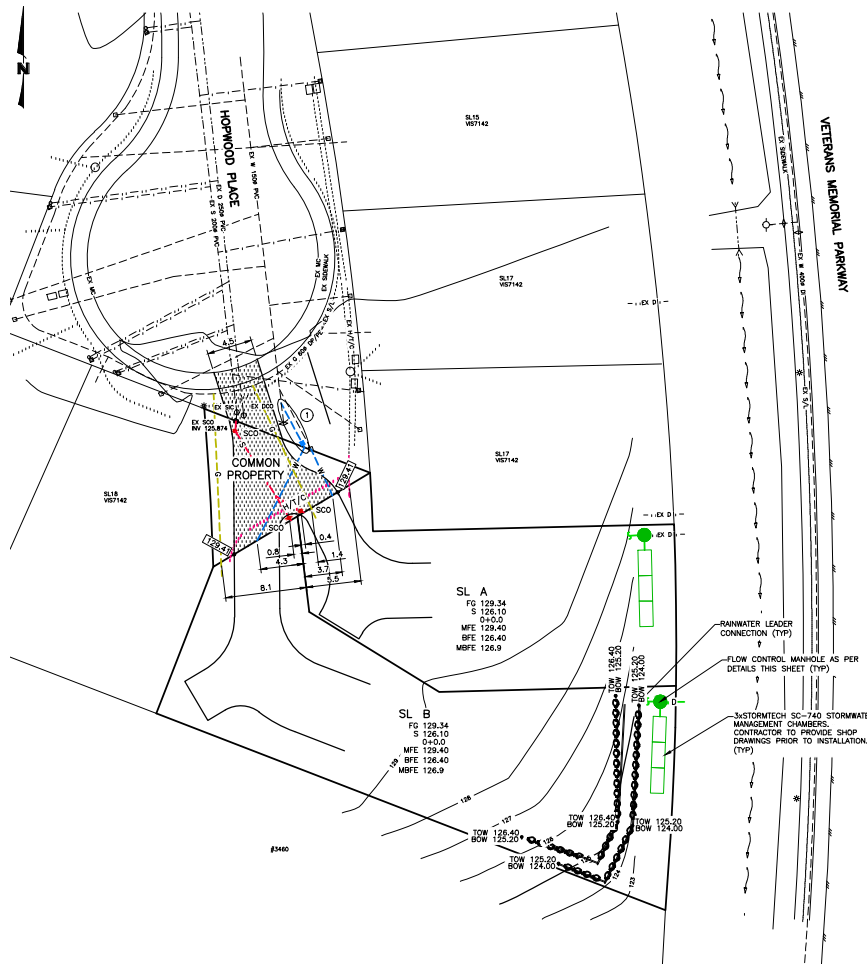
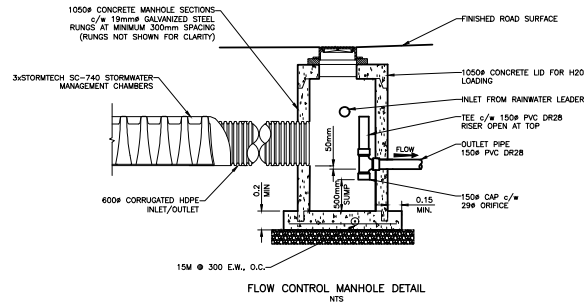

LOCATION PLAN  
N.T.S.  
PROPOSED SUBDIVISION OF LOT B, SECTION 63,  
ESQUIMALT DISTRICT, PLAN V989431  
0 5 15m

No.	DATE	REVISION	ENGR	EXISTING	PROPOSED	EXISTING	PROPOSED	EXISTING	PROPOSED	EXISTING	PROPOSED
1	23-06-13	SWMP REVISION	BB/KK	MANHOLE	MANHOLE	AIR VALVE	AIR VALVE	SANITARY	SANITARY	FENCE	FENCE
				CLEANOUT	CLEANOUT	WATER METER	WATER METER	SANITARY FOREMAN	SANITARY FOREMAN	SLOPE - TOP	SLOPE - TOP
				LEFT STATION	LEFT STATION	IRRIGATION VALVE	IRRIGATION VALVE	STORM DRAIN	STORM DRAIN	SLOPE - BOTTOM	SLOPE - BOTTOM
				INSPECTION CHAMBER	INSPECTION CHAMBER	UTILITY MANHOLE *	UTILITY MANHOLE *	WATER	WATER	CONTOUR - MAJOR	CONTOUR - MAJOR
				CATCH BASIN	CATCH BASIN	SERVICE BOX *	SERVICE BOX *	GAS	GAS	CONTOUR - MINOR	CONTOUR - MINOR
				SILT TRAP	SILT TRAP	LPT	LPT	ELECTRICAL	ELECTRICAL	BOUNDARY	BOUNDARY
				SEEPAGE PIT	SEEPAGE PIT	UTILITY POLE *	UTILITY POLE *	ROAD CURB	ROAD CURB	N/A	N/A
				CULVERT	CULVERT	POLE-MOUNT LS	POLE-MOUNT LS	EDGE OF PAVEMENT	EDGE OF PAVEMENT	BUILDING ENVELOPE	BUILDING ENVELOPE
				DITCH	DITCH	ORNAIMENTAL LUMINAIRE	ORNAIMENTAL LUMINAIRE	SIDEWALK	SIDEWALK	VEGETATION LINE	VEGETATION LINE
				HYDRANT	HYDRANT	TRAFFIC SIGNAL	TRAFFIC SIGNAL	PROPERTY LINE	PROPERTY LINE	BENCHMARK	BENCHMARK
				WATER VALVE	WATER VALVE			EASEMENT	EASEMENT	ELEVATION:	ELEVATION:
				FLUSH VALVE	FLUSH VALVE						

**WESTBROOK Consulting Ltd.**  
 #115 - 866 Goldstream Ave., Victoria, BC V9B 0J3  
 Telephone: 250-391-8592 Facsimile: 250-391-8593

**Colwood**  
 DESIGN IK  
 DRAWN BB  
 CHECKED  
 ENGINEER MW

**3469 HOPWOOD PLACE**  
 CACTUS DEVELOPMENTS LTD.  
 SITE PLAN  
 GENERAL NOTES  
 DATE: FEB 2023  
 DRAWING NO. 386001

COLWOOD FILE NO. SUB22-012  
 COLWOOD CONTRACT NO.  
 SCALE: 1:250  
 N/A  
 SHEET: 1 OF 1  
 REV: 1



The intended plot size of this plan is 432mm in width by 280mm in height, B size, when plotted at a scale of 1:250.

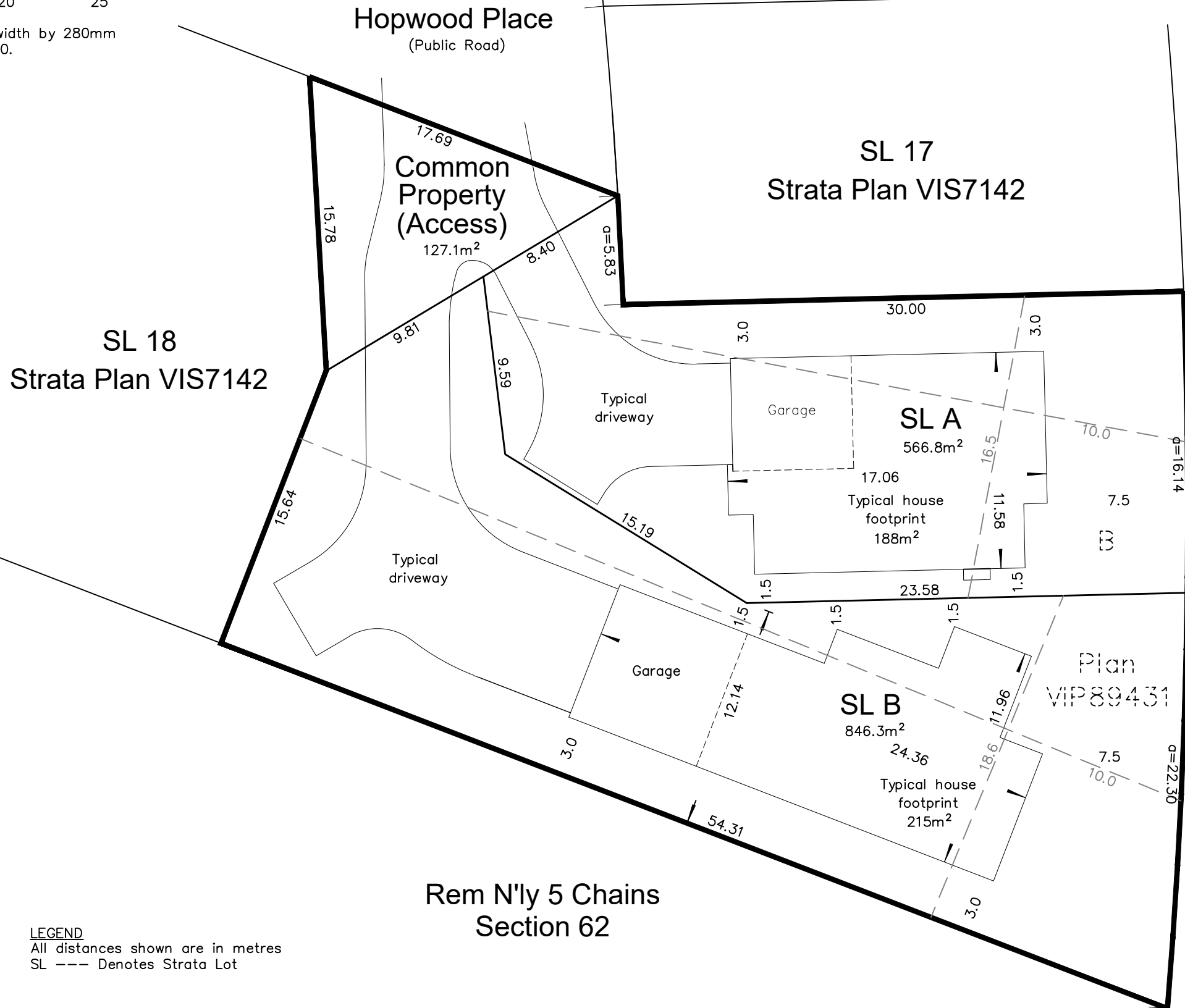
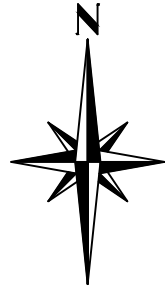

**Tentative Bare Land Strata Plan**

**Cactus Developments**

LOT B,  
SECTION 63,  
ESQUIMALT DISTRICT,  
PLAN VIP89431

ADDRESS : 3469 Hopwood Place

PROJECT SURVEYOR : PJW

DRAWN BY : PJW      DATE : Mar 15/23

OUR FILE : 34133      REVISION :

**JEA** J. E. ANDERSON & ASSOCIATES  
SURVEYORS - ENGINEERS

4212 GLANFORD AVE, VICTORIA, B.C. V8Z 4B7  
TEL: 250-727-2214 FAX: 250-727-3395  
E-MAIL : info@jeanderson.com  
VICTORIA-NANAIMO-PARKSVILLE-CAMPBELL RIVER

**LEGEND**  
All distances shown are in metres  
SL --- Denotes Strata Lot

Parent lot (Lot B) dimensions are based on existing survey plans registered in the Land Title Office.  
Subject to charges, legal notations, and interests shown on:  
Title No. CA9940406 (P.I.D. 028-916-221)